



公司简介

COMPANY PROFILE

莱州市鲁博机械有限公司成立于2009年9月，座落于全国工程机械生产基地山东莱州市，位于206国道处，占地面积30000平方米，员工50余人，交通便利，风景宜人，有着得天独厚的地理位置。主要从事工程机械，建筑机械的研发与制造，2014年自主研发打造出国内第一台液压行走的自料搅拌机，通过公司不断的改良改进，2015年公司正式将产品推入市场销售，广泛应用于混凝土道路铺设，建筑工程混凝土搅拌，赢得了客户的普遍赞誉，为广大客户创造了良好的生产效益，目前是国内自料搅拌机行业规模最大、产品品种与系列最齐全、最具竞争力和影响力的公司。

2015年公司引进了具有先进水平的机械制造三维设计软件，并与国内名校、企业建立良好的技术合作关系，使公司拥有了独立研发高新技术产品的能力，形成了以自主知识产权为核心的完善的科研体系。产品系列方面，公司形成了从JBC1.2至JBC4.0自料搅拌机系列产品格局。至今公司拥有30多项国家专利证书，率先通过CE欧盟国家质量体系认证的公司。

公司建立了覆盖全国的营销网络，已出口到世界30多个国家和地区，连续5年保持行业销售额首位，我公司凭借科学的决策，坚持“质量第一，用户至上，诚信守誉”的企业方针，秉承“团结务实、开拓创新”的企业精神，以“鲁博机械，只做精品”为己任，以“人才为根本，市场为导向，以质量创品牌，创新促发展”的经营理念，打造专业的自料搅拌机研发生产基地。

公司坚持“解决售前、售后无忧”的服务宗旨，塑造了一批高素质高效率的营销服务团队。公司产品以其优美的外观、可靠的性能、适中的价格、优质的服务而饮誉祖国大江南北，并出口亚、非、欧等国家。

我们愿凭着重合同、守信誉的原则，以提供优良的产品，优质的服务为宗旨，共创美好明天！

公司荣誉

COMPANY HONOR





COMPANY PROFILE

Laizhou Luzun Machinery Co., Ltd. was established in September 2009, which is located in the national engineering machinery production base of Laizhou City, Shandong Province. Our factory is beside of National Highway 206, and covers an area of 30,000 square meters with more than 50 employees. Also has convenient transportation and pleasant scenery. LUZUN machinery is mainly engaged in the research and development and manufacturing of construction machinery. In 2014, it independently developed the first self-Loading Concrete mixer for hydraulic walking Type in China. Through the continuous improvement of the company, the company's products were officially put into the market in 2015. It is applied to concrete road paving and concrete mixing of construction projects, which has won widespread praise from customers and created good production benefits for customers. At present, it is the largest self-feeding mixer industry, with the most complete varieties, the most competitive and influential company in China.

In 2015, the company introduced advanced three-dimensional design software for machinery manufacturing, and established good technical cooperation relationship with famous universities and enterprises in China, which enabled the company to independently develop high-tech products and formed perfection with independent intellectual property ability and scientific research system. In terms of product range, the company formed a series of self-Loading Concrete mixers from JBC1.2 to JBC4.0. Up to now, the company has more than 30 national patent certificates, and is the first company to pass the CE European quality system certification. The company has established a nationwide marketing network and has exported to more than 30 countries and regions in the world. It has maintained the top sales in the industry for five consecutive years. With scientific decision-making, our company adheres to the principle of "quality first, customer first, integrity and reputation". The corporate policy is adhering to the enterprise spirit of "unity and pragmatic, pioneering and innovative", takes "LUZUN machinery, PERFECT products" as its mission, and takes "people-oriented, market-oriented, quality-oriented, innovation-driven development" business philosophy, to create a professional self-Loading Concrete mixer research and development production base. The company adheres to the service tenet of "solving pre-sales and after-sales worry-free". Created a group of high-quality and efficient marketing service team. The company's products are well-known for their beautiful appearance, reliable performance, moderate price and excellent service, and welcomed by lots of clients of Asia, Africa and Europe. We are willing to provide excellent products and excellent service for the purpose of creating a better tomorrow with the principle of focusing on contracts and keeping promises!

COMPANY HONOR



1.6方(带旋转)自动上料搅拌机

JBC1.6/1.6R

Self Propelled Concrete Mixer



参数说明

Parameter description

柴油发动机

型号: YCD4T22T-105
 最大功率: 78千瓦 (106马力)
 最大扭矩: 330牛米@2400转/分钟

电气系统

发电机: 28V-500Wa (18A)
 蓄电池: 2×12V-60AH (272A)
 道路照明系统

4*4四轮驱动

全时四驱动力 时速0-23公里/小时
 液力变矩器变速箱, 开式液压齿轮油泵。

轴和轮胎

轮边减速桥, 桥上配置行星减速齿轮,
 法兰连接变速箱。
 轮胎: ... 20.5-16PR, 最大负重: 2840kg。

制动器

内部轮毂式行车制动器和紧急制动器作用
 于4个轮子, 使用独立双回路上的小型伺
 服泵启用。

设备液压系统

齿轮泵: 品牌 德鸿
 铝质热交换器, 用于冷却液压油。
 开式进油, 可以从外部更换液压油过滤器。

搅拌和卸载

双锥形滚筒拥有双螺旋形搅拌螺杆和中凸底部。
 滚筒几何容量: 2900升
 滚筒旋转速度: 16转/分钟。
 混凝土产量: 1.6立方米/罐

转向

铰接转向

供水系统

“自吸式”24V大容量水泵, 拥有速吸功能。
 定量上水控制器, 搅拌更均匀, 更符合标准。

操作室

封闭的操作室可选制热/冷系统, 倾斜式前窗。
 人性化座椅, 配置柔性悬架和高度调整功能。

维护加注量

燃油箱: 100升
 液压系统总容量: 100升
 机油: 16升

重量

操作重量: 5800千克
 最大总重量: 9640千克
 最大载重量: 3840千克



可侧方卸料

锰钢罐体
结实耐用罐架升降
卸料彻底更快上水控制器
定量调节

马达散热器



JBC1.6/1.6R

Self Propelled Concrete mixer



Parameter Description

Diesel engine

Model: YCD4T22T-105
Maximum power: 78kW (106 hp)
Maximum torque: 330Nm@2400rev / min

Electrical System

Generator: 28V-500Wa (18A)
Battery: 2×12V-60AH (272A)
Road lighting system

4*4 four-wheel drive

Full-time four-drive speed is 0-23 km / h
Torque converter gearbox, open hydraulic gear pump.

Shaft and tire

Wheel-side Deceleration Bridge with planetary reduction gears on the bridge and flanged gearbox.
Tires: ... 20.5-16PR, Maximum loads: 2840kg.

Brake

The internal hub-type service brakes and emergency brakes act on 4 wheels and are activated using a small servo pump on a separate dual circuit.

Equipment hydraulic system

Gear pump: Brand "Dehong"
Aluminum heat exchanger is used for cooling hydraulic oil.
Open oil inlet, hydraulic oil filter can be replaced externally.

Stirring and unloading

The double cone Drum has a double spiral agitating screw and a convex bottom.
Drum geometry:..... 2900Liters
Drum rotation speed:..... 16Rev / min.
Concrete production:..... 1.6Cubic Meters / Drum

Steering

Articulated steering

Water supply system

"Self-suction" 24V large capacity pump with quick suction function. Quantitative water supply controller, the mixing is more uniform and more in line with the standard.

Operating Cab

The enclosed operating room is available with a heated/cold system and a tilted front window. Humanize seat with flexible suspension and height adjustment.

Maintenance amount

Fuel tank: 100 liters
Total hydraulic system capacity:..... 100 liters
Engine oil:..... 16 liters

Weight

Operating weight: 5800 kg
Maximum total weight: 9640 kg
Maximum load: 3840 kg



Side discharge



Manganese steel tank, durable



water controller quantitative adjustment



Motor radiator



2.0方(带旋转)自动上料搅拌机

JBC2.0/2.0R

Self Propelled Concrete Mixer



参数说明

Parameter description

柴油发动机

型号: YCD4T22T-105
 最大功率: 78千瓦 (106马力)
 最大扭矩: 330牛米@2400转/分钟

电气系统

发电机: 28V-500Wa (18A)
 蓄电池: 2×12V-60AH (272A)
 道路照明系统

4*4四轮驱动

全时 四驱动力 时速0-23公里/小时
 液力变矩器变速箱, 开式液压齿轮油泵。

轴和轮胎

轮边桥, 桥上配置行星减速齿轮, 法兰连接变速箱。
 后桥, 摆动(±28°), 桥上配置摇摆车架。
 轮胎: ... 20.5-16, 最大负重: 2840kg

制动器

内部轮鼓式行车制动器和紧急制动器作用于4个轮子, 使用独立双回路上的小型伺服器启用。

设备液压系统

齿轮泵: 品牌 德鸿
 铝质热交换器, 用于冷却液压油。
 开式进油, 可以从外部更换液压油过滤器。

搅拌和卸载

双锥形滚筒拥有双螺旋形搅拌螺杆和中凸底部。
 滚筒几何容量: 3900升
 滚筒旋转速度: 16转/分钟
 混凝土产量: 2.0-2.4立方米/罐

转向

铰接转向

供水系统

“自吸式”24V大容量水泵, 拥有速吸功能。
 定量上水控制器, 搅拌更均匀, 更符合标准。

操作室

封闭的操作室可选制热/冷系统, 倾斜式前窗。
 人性化座椅, 配置柔性悬架和高度调整功能。

维护加注量

燃油箱: 100升
 液压系统总容量: 100升
 机油: 16升

重量

操作重量: 6100千克
 最大总重量: 10900千克
 最大载重量: 4800千克



驾驶室



加长料槽



操作手柄



高清摄像头



大臂三连杆

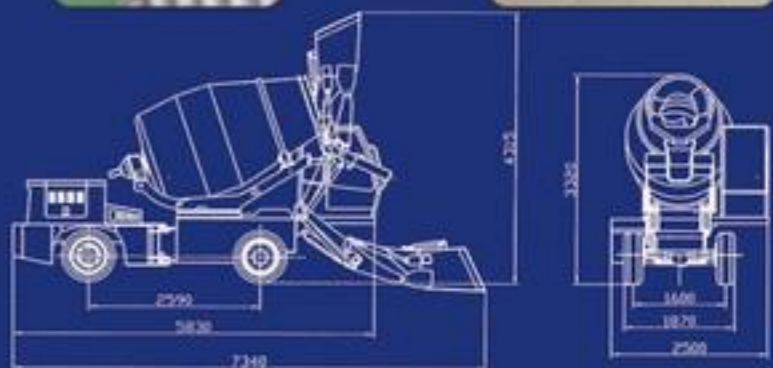

JBC2.0/2.0R

Self Propelled Concrete mixer



Parameter Description

Diesel engines

Model: YCD4T22T-105
Maximum power: 78kW (106hp)
Maximum torque: 330Nm@2400rev / min

Electrical System

Generator: 28V-500Wa (18A)
Battery: 2×12V-60AH (272A)
Road lighting system

4*4 four-wheel drive

Full-time four driving force 0-23 km / h
Torque converter gearbox,
Open hydraulic gear oil pump.

Axles and tires

Wheel-side Deceleration Bridge with planetary reduction gears on the bridge and flanged gearbox.
Tires: ... 20.5-16PR,
Maximum loads: 2840kg.

Brake

The internal hub-type service brakes and emergency brakes act on 4 wheels and are activated using a small servo pump on a separate dual circuit.

Equipment hydraulic system

Gear pump: Brand "Dehong"
Aluminum heat exchanger is used for cooling hydraulic oil.
Open oil inlet, hydraulic oil filter can be replaced externally.

Stirring and unloading

The double cone Drum has a double spiral agitating screw and a convex bottom.
Drum geometry: 3900 Liters
Drum rotation speed: 16 Rev / min.
Concrete production: 2.0-2.4Cubic Meters / Drum

Steering

Articulated steering

Water supply system

"Self-suction" 24V large capacity pump with quick suction function.
Quantitative water supply controller, the mixing is more uniform and more in line with the standard.

Operating Cab

The enclosed operating room is available with a heated/cold system and a tilted front window. Humanize seat with flexible suspension and height adjustment.

Maintenance amount

Fuel tank: 100 liters
Total hydraulic system capacity 100 liters
Engine oil: 16 liters

Weight

Operating weight: 6100 kg
Maximum total weight: 10900kg
Maximum load: 4800 kg



Cab



Extended Chute



operating handle



HD camera



Three-link boom



3.0方(带旋转)自动上料搅拌机

JBC3.0R/3.0R (驾驶室同步旋转)

Self Propelled Concrete Mixer



参数说明 Parameter description

柴油发动机

型号: YCD4J22G
 最大功率: 85千瓦 (116马力)
 最大扭矩: 390牛米@2800转/分钟

电气系统

发电机: 28V-1500Wa (53.5A)
 蓄电池: 2×12V-60AH (272A)
 道路照明系统

4*4四轮驱动

全时 四驱动力 时速0-36公里/小时
 液力变矩器变速箱, 开式液压齿轮油泵。

轴和轮胎

加重专用桥, 桥上配置行星减速齿轮, 法兰连接变速箱。
 后桥, 摆动(±28°), 桥上配置摇摆车架。
 轮胎: ... 16-70-20PR,
 最大载重: 5150kg, 450kPa

制动器

设备采用碟式行车制动器和紧急制动器作用于4个轮子,
 使用独立双停车制动。

设备液压系统

铝质热交换器, 用于冷却液压油。
 开式进油, 可以从外部更换液压油过滤器。

搅拌和卸载

双锥形滚筒拥有双螺旋形搅拌螺杆和中凸底部。
 滚筒几何容量: 4650L
 滚筒旋转速度: 16 转/分钟。
 混凝土产量: 2.8之3.0立方米/罐

转向

铰接转向

供水系统

“自吸式”24V大容量水泵, 拥有速吸功能。
 定量上水控制器, 搅拌更均匀, 更符合标准。

操作室

封闭的操作室可选制热/冷系统, 倾斜式前窗。
 人性化座椅, 配置柔性悬架和高度调整功能。

维护加注量

燃油箱: 120升
 液压系统总容量: 100升
 机油: 20升

重量

操作重量: 7500千克
 最大总重量: 14700千克
 最大载重量: 7200千克

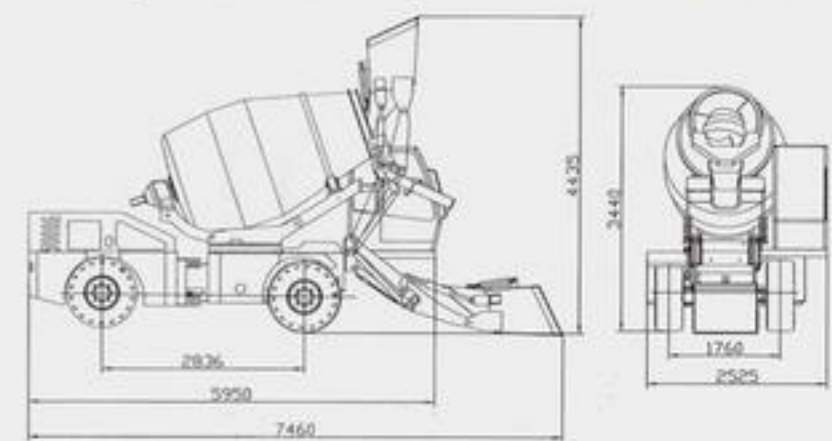

JBC3.0/3.0R

Self Propelled Concrete mixer



Parameter Description

Diesel engine

Model: YCD4J22G
Maximum power: 85 kW (116 hp)
Maximum torque: 390 Nm @ 2800 rev / min

Electrical System

Generator: 28V-1500Wa (53.5A)
Battery: 2×12V-60AH (272A)
Road lighting system

4*4 four-wheel drive

Full-time four-drive speed is 0-36 km / h
Torque converter gearbox, open hydraulic gear pump.

Shaft and tire

Aggravated special bridge, the planetary reduction gear, the flanged gear box
Rear axle, swing ($\pm 28^\circ$), and swinging frame on the bridge. Tires: ... 16-70-20PR,
Maximum load: 5150kg, 450kPa

Brake

The device uses a butterfly service brake and an emergency brake to act on four wheels and uses a separate double parking brake.

Equipment hydraulic system

Aluminum heat exchanger is used for cooling hydraulic oil.
Open oil inlet, hydraulic oil filter can be replaced externally.

Stirring and unloading

The double cone Drum has a double spiral agitating screw and a convex bottom.
Drum geometry: 4650 Liters
Drum rotation speed: 16 Rev / min.
Concrete production: 2.8-3.0 Cubic Meters / Drum

Steering

Articulated steering

Water supply system

"Self-suction" 24V large capacity pump with quick suction function.
Quantitative water supply controller, the mixing is more uniform and more in line with the standard.

Operating Cab

The enclosed operating room is available with a heated/cold system and a tilted front window.
Humanize seat with flexible suspension and height adjustment.

Maintenance amount

Fuel tank: 120 liters
Total hydraulic system capacity 100 liters
Engine oil: 20 liters

Weight

Operating weight: 7500 kg
Maximum total weight: 14700 kg
Maximum load: 7200 kg

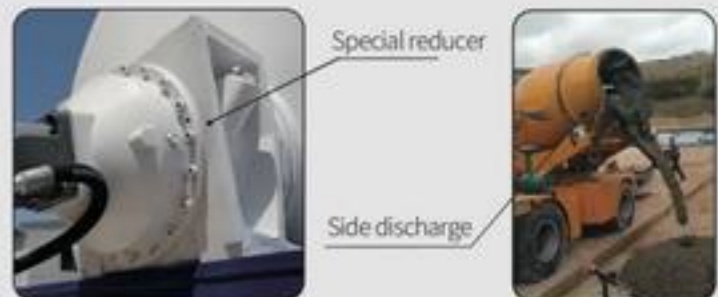

Special reducer

Side discharge

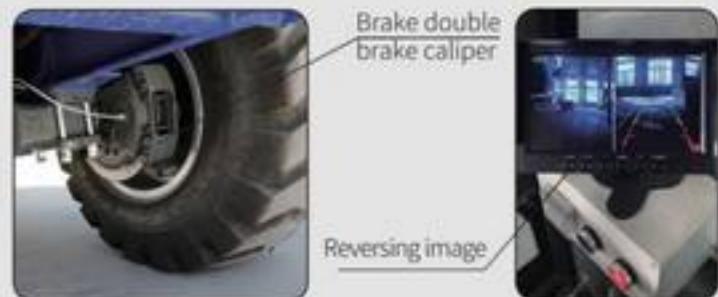

Brake double brake caliper

Reversing image



Special bridge

tank lifting more complete discharge

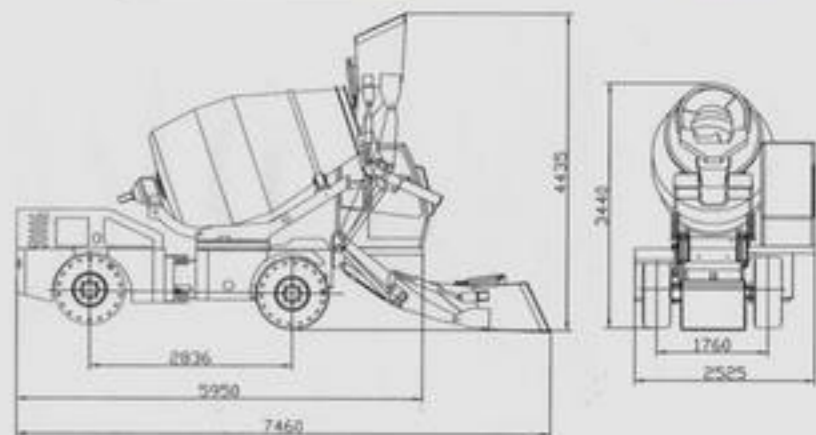

3.5方(带旋转)自动上料搅拌机 JBC3.5R/3.5R (驾驶室同步旋转)

Self Propelled Concrete Mixer



18

参数说明 Parameter description

柴油发动机

型号: YCD4J22G
最大功率: 85千瓦 (116马力)
最大扭矩: 390牛米@2800转/分钟

电气系统

发电机: 28V-1500Wa (53.5A)
蓄电池: 2×12V-60AH (272A)
道路照明系统

4*4四轮驱动

全时 四驱动力 时速0-36公里/小时
液力变矩器变速箱, 开式液压齿轮油泵。

轴和轮胎

加重专用桥, 桥上配置行星减速齿轮, 法兰连接变速箱。
后桥, 摆动(± 28°), 桥上配置摆动车架。
轮胎: ... 16-70-20PR,
最大载重: 5150kg, 450kPa

制动器

设备采用碟式行车制动器和紧急制动器作用于4个轮子, 使用独立双停车制动。

设备液压系统

铝质热交换器, 用于冷却液压油。
开式进油, 可以从外部更换液压油过滤器。

搅拌和卸载

双锥形滚筒拥有双螺旋形搅拌螺杆和中凸底部。
滚筒几何容量: 5150L
滚筒旋转速度: 16 转/分钟
混凝土产量: 3.3之3.5立方米/罐

转向

铰接转向

供水系统

“自吸式”24V大容量水泵, 拥有速吸功能。
定量上水控制器, 搅拌更均匀, 更符合标准。

操作室

封闭的操作室可选制热/冷系统, 倾斜式前窗。
人性化座椅, 配置柔性悬架和高度调整功能。

维护加注量

燃油箱: 120升
液压系统总容量: 100升
机油: 20升

重量

操作重量: 7800千克
最大总重量: 16200千克
最大载重量: 8400千克

侧方卸料



水箱



大容量水箱

专用水泥料斗



先导操作手柄



发动机

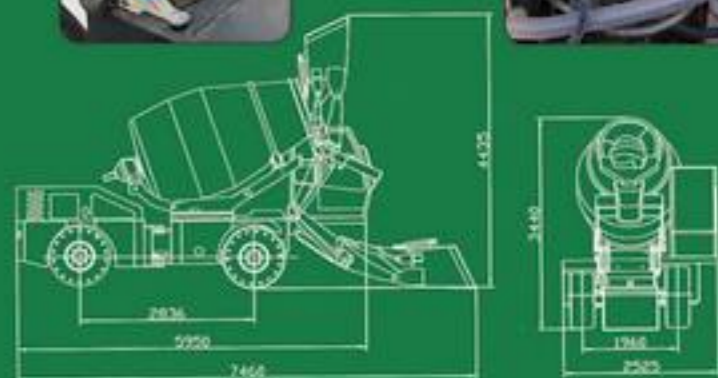

JBC3.5/3.5R

Self Propelled Concrete mixer



Parameter Description

Diesel engines

Model: YCD4J22G
Maximum power: 85 kW (116 hp)
Maximum torque: 390 Nm @2800 rev / min

Electrical System

Generator: 28V-1500Wa (53.5A)
Battery: 2× 12V-60AH (272A)
Road lighting system

4*4 four-wheel drive

Full-time four driving force 0-36 km / h
Torque converter gearbox,
Open hydraulic gear oil pump.

Axles and tires

Aggravated special bridge, the planetary reduction gear,
the flanged gear box
Rear axle, swing (± 28°), and swinging frame on the bridge.
Tires: 16-70-20PR, Maximum load: 5150kg, 450kPa

Brake

The device uses a butterfly service brake and an
emergency brake to act on four wheels and uses
a separate double parking brake.

Equipment hydraulic system

Aluminum heat exchanger for cooling hydraulic oil.
Open oil inlet, hydraulic oil filter can be replaced
externally.

Stirring and unloading

The double cone Drum has a double spiral
agitating screw and a convex bottom.
Drum geometry: 5150L
Drum rotation speed: 16 rpm.
Concrete production: 3.3-3.5 cubic meters / Drum

Steering

Articulated steering

Water supply system

"Self-suction" 24V large capacity pump with
quick suction function.
Quantitative water supply controller, the mixing is
more uniform and more comfortable with the standard.

Operating Cab

The enclosed operating room has a heating/cooling
system with a sloping front window.
Humanize seat with flexible suspension
and height adjustment.

Maintenance amount

Fuel tank: 120 liters
Hydraulic system Total capacity: 100 liters
Engine oil: 20 liters

Weight

Operating weight: 7800 kg
Maximum total weight: 16200 kg
Maximum load capacity: 8400 kg



Rotating
seat cab



large capacity
water tank



Special cement
hopper



Pilot operated
handle



Swivel center



Engine



LZ3500 (带旋转) 自动上料搅拌机

LZ3500

Self Propelled Concrete Mixer

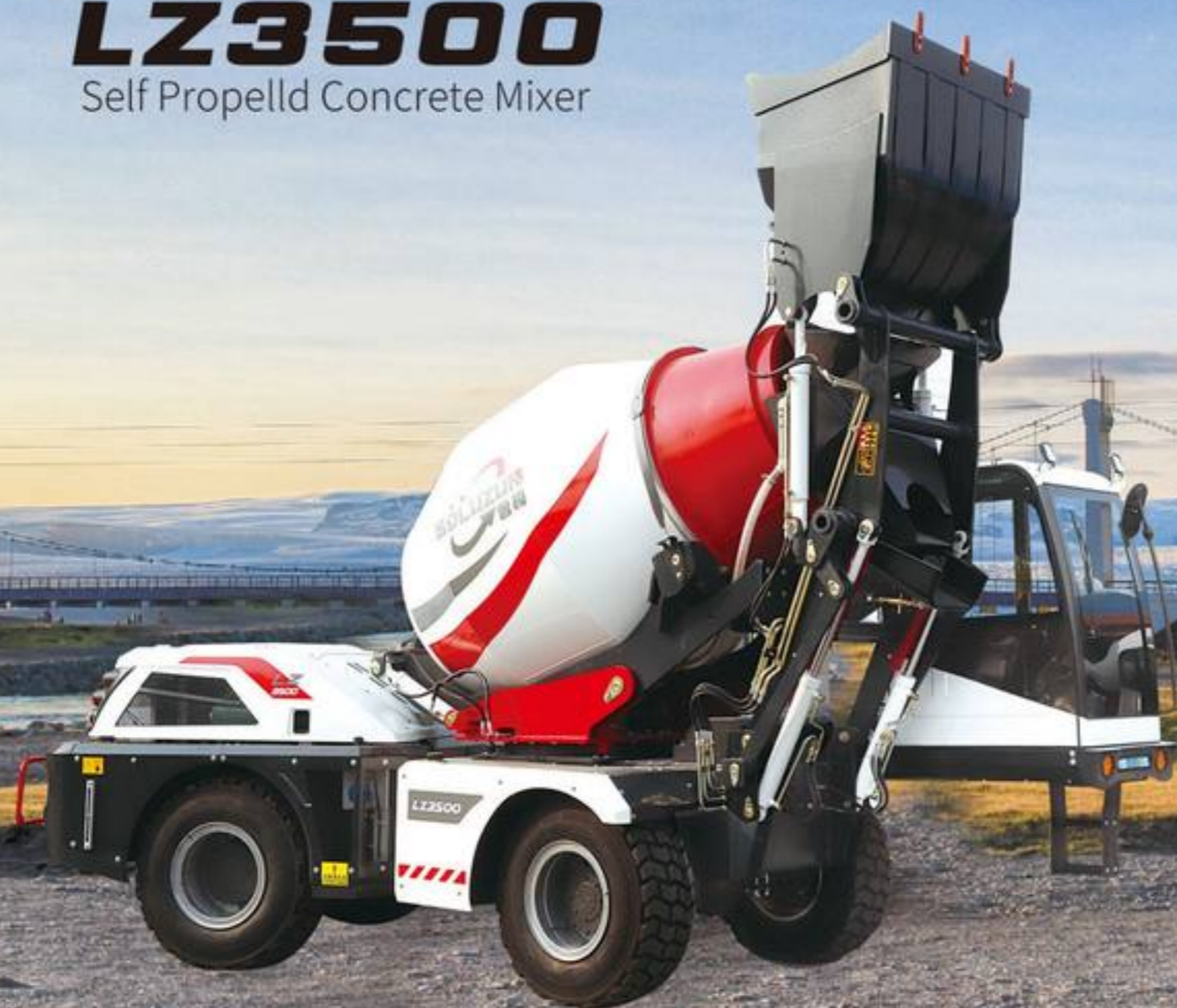

06

参数说明
Parameter description

柴油发动机

型号: YCD4J22G
 最大功率: 85千瓦 (116马力)
 最大扭矩: 390牛米@2800转/分钟

电气系统

发电机: 28V-1500Wa (53.5A)
 蓄电池: 2×12V-60AH (272A)
 道路照明系统

4*4四轮驱动

全时 四驱动力 时速0-36公里/小时
 液力变矩器变速箱, 开式液压齿轮油泵。

轴和轮胎

加重专用桥, 配置行星减速齿轮, 法兰连接变速箱。
 后桥, 摆动(±28°), 桥上配置摆动车架。
 轮胎: 16-70-20PR, 最大载重: 5150kg, 450kPa

制动器

设备采用碟式行车制动器和紧急制动器作用于4个轮子, 使用独立双停车制动。

维护加注量

燃油箱: 128升
 液压系统总容量: 100升
 机油: 20升

操作室

封闭的操作室拥有制热/冷系统, 倾斜式前窗, 人性化座椅, 配置柔性悬架和高度调整功能。

高压洗车

配备高压洗车泵。

搅拌和卸载

双锥形滚筒拥有双螺旋形搅拌螺杆和中凸底部。
 滚筒几何容量: 5150L
 滚筒旋转速度: 16 转/分钟
 混凝土产量: 3.3-3.5立方米/罐

转向

铰接转向

设备液压系统

柱塞式液压马达
 铝质热交换器, 用于冷却液压油。
 开式进油, 可以从外部更换液压油过滤器。

重量

操作重量: 8500千克
 最大总重量: 16900千克
 最大载重量: 8400千克

供水系统

“自吸式”24V大容量水泵, 拥有速吸功能。

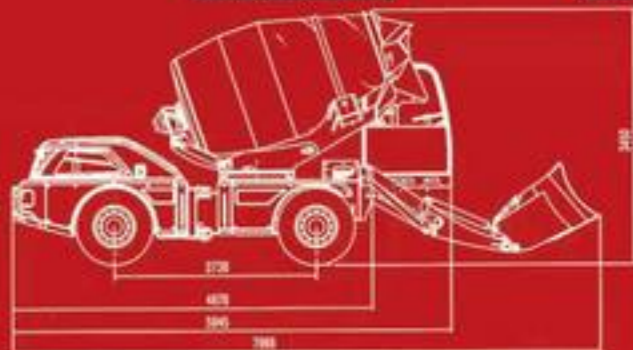

驾驶室

专用散热器
内置更安全新式液压管路
不折管高压洗车泵
清洗无残留圆弧式料斗
不存料料斗可下翻
方便装卸

LZ3500

Self Propelled Concrete mixer



Parameter Description

Diesel engines

Model: YCD4J22G
Maximum power: 85 kW (116 hp)
Maximum torque: 390 Nm @2800 rev / min

Electrical System

Generator: 28V-1500Wa (53.5A)
Battery: 2 × 12V-60AH (272A)
Road lighting system

4*4 four-wheel drive

Full-time four driving force 0-36 km / h
Torque converter gearbox,
Open hydraulic gear oil pump.

Axles and tires

Aggravated special bridge, the planetary reduction gear, the flanged gear box
Rear axle, swing ($\pm 28^\circ$), and swinging frame on the bridge.
Tires: 16-70-20PR, Maximum load: 5150kg, 450kPa

Brake

The device uses a butterfly service brake and an emergency brake to act on four wheels and uses a separate double parking brake.

Maintenance amount

Fuel tank: 128 liters
Hydraulic system Total capacity: 100 liters
Engine oil: 20 liters

Operating Cab

The enclosed operating room has a heating/cooling system with a sloping front window.
Humanize seat with flexible suspension and height adjustment.

High pressure car wash pump

Equip a high pressure car wash pump.

Stirring and unloading

The double cone Drum has a double spiral agitating screw and a convex bottom.
Drum geometry: 5150L
Drum rotation speed: 16 rpm.
Concrete production: 3.3-3.5 cubic meters / Drum

Steering

Articulated steering

Equipment hydraulic system

Piston type hydraulic motor,
Aluminum heat exchanger for cooling hydraulic oil.
Open oil inlet, hydraulic oil filter can be replaced externally.

Weight

Operating weight: 8500kg
Maximum total weight: 16900kg
Maximum load capacity: 8400kg

Water supply system

"Self-suction" 24V large capacity pump with quick suction function.



Cab



Professional radiator



installed a safer unfolded HYD oil pipe



High-pressure car wash pump



circular hopper does not left material



and hopper can be turned down for easy loading and unloading



LZ4000

Self Propelled Concrete Mixer



参数说明 Parameter description

柴油发动机

型号: YCD4J22G
最大功率: 85/95KW (116/129马力)
最大扭矩: 440牛米@2800转/分钟

电气系统

发电机: 28V-1500Wa (53.5A)
蓄电池: 2×12V-80AH (343A)
道路照明系统

4*4四轮驱动

全时 四驱动力 时速0-36公里/小时
液力变矩器变速箱, 开式液压齿轮油泵。

轴和轮胎

10T液压轮边桥, 桥上配置行星减速齿轮,
法兰连接变速箱。
全车整体车架, 后轮双弹簧减震钢板。
轮胎: ... 16-70-20PR, 最大负重: 5150kg, 450kPa

制动器

设备采用碟式行车制动器和紧急制动器作用于4个轮子, 使用独立双停车制动。

设备液压系统

铝质热交换器, 用于冷却液压油。
开式进油, 可以从外部更换液压油过滤器。

搅拌和卸载

双锥形滚筒拥有双螺旋形搅拌螺杆和中凸底部。
滚筒几何容量: 6100L
滚筒旋转速度: 15转/分钟
混凝土产量: 4.0立方米/罐

转向

整体车架前轮转向

供水系统

“自吸式”24V大容量水泵, 拥有透吸功能。
定量上水控制器, 搅拌更均匀, 更符合标准。

操作室

封闭的操作室拥有制热/冷系统, 倾斜式前窗。
配备液压电子秤精准计量。
人性化座椅, 配置柔性悬架和高度调整功能。

维护加注量

燃油箱: 135升
液压系统总容量: 240升
机油: 16升

重量

操作重量: 8800千克
最大总重量: 18400千克
最大载重量: 9600千克



冷暖空调



进口柱塞马达
强劲耐用



车窗防护网



防撞杠



摇摆滑轮



车灯



Parameter Description

Diesel engine

Model:YCD4J22G
 Maximum power: 85/95KW (116/129 hp)
 Maximum torque:440Nm@2800 Rev / min

Electrical System

Generator:28V--1500Wa (53.5A)
 Battery:2×12V--80AH (343A)
 Road lighting system

4*4 four-wheel drive

Full-time four-drive speed is 0-23 km / h
 Torque converter gearbox, open hydraulic gear pump.

Shaft and tire

10T hydraulic wheel side bridge with planetary reduction gears on the bridge and flanged gearbox. The whole vehicle frame, the rear wheels have double spring shock absorbing steel plate. Tires: 16-70-20PR, Maximum load: 5150kg, 450kPa

Brake

The device uses a disc brake and an emergency brake on four wheels, using a separate double parking brake.

Equipment hydraulic system

Aluminum heat exchanger is used for cooling hydraulic oil. Open oil inlet, hydraulic oil filter can be replaced externally.

Stirring and unloading

The double cone Drum has a double spiral agitating screw and a convex bottom.
 Drum geometry:..... 6100L
 Drum rotation speed:15rpm / min.
 Concrete production:4.0cubic meters / Drum

Steering

Articulated steering

Water supply system

"Self-suction" 24V large capacity pump with quick suction function.
 Quantitative water supply controller, the mixing is more uniform and more in line with the standard.

Operating Cab

The enclosed operating room is available with a heated/cold system and a tilted front window. Humanize seat with flexible suspension and height adjustment.

Maintenance amount

Fuel tank: 135 liters
 Total hydraulic system capacity: 240 liters
 Engine oil: 16 liters

Weight

Operating weight:8800kg
 Maximum total weight:.....18400kg
 Maximum load:9600kg



Air-conditioning



Imported Piston motor, strong and durable



window protection net



Anti-collision bar



Swing pulley



Light



LZ4000

Self Propelled Concrete mixer

4.0方(带旋转)自动上料搅拌机

JBC4.0/4.0R

Self Propelled Concrete Mixer



20

参数说明

Parameter description

柴油发动机

型号: YCD4J22G
 最大功率: 85/95KW (116/129马力)
 最大扭矩: 440牛米@2800转/分钟

电气系统

发电机: 28V-1500Wa (53.5A)
 蓄电池: 2×12V-100AH (454A)
 道路照明系统

4*4四轮驱动

全时四驱动力 时速0-36公里/小时
 液力变矩器变速箱, 开式液压齿轮油泵。

轴和轮胎

10T液压轮边桥, 桥上配置行星减速齿轮,
 法兰连接变速箱。
 全车整体车架, 后轮双弹簧减震钢板。
 轮胎: ... 16-70-20PR, 最大负重: 5150kg, 450kPa

制动器

设备采用碟式行车制动器和紧急制动器作用于4个轮子, 使用独立双停车制动。

设备液压系统

铝质热交换器, 用于冷却液压油。
 开式进油, 可以从外部更换液压油过滤器。

搅拌和卸载

双锥形滚筒拥有双螺旋形搅拌螺杆和中凸底部。
 滚筒几何容量: 6100L
 滚筒旋转速度: 15转/分钟
 混凝土产量: 4.0立方米/罐

转向

整体车架前轮转向

供水系统

“自吸式”24V大容量水泵, 拥有速吸功能。
 定量上水控制器, 搅拌更均匀, 更符合标准。

操作室

封闭的操作室拥有制热/冷系统, 倾斜式前窗。
 配备液压电子秤精准计量。
 人性化座椅, 配置柔性悬架和高度调整功能。

维护加注量

燃油箱: 135升
 液压系统总容量: 240升
 机油: 16升

重量

操作重量: 8800千克
 最大总重量: 18400千克
 最大载重量: 9600千克

多方位卸料



整体水箱



自动打黄油



10T液压轮边驱动桥

转罐控制杆
转罐速度可调节

液压电子秤



JBC4.0/4.0R

Self Propelled Concrete mixer



Parameter description

Diesel engines

Model: YCD4J22G
Maximum power: 85/95 kW (116/129 hp)
Maximum torque: 440 Nm @2800 rev / min

Electrical System

Generator: 28V-1500Wa (53.5A)
Battery: 2 × 12V-80AH (343A)
Road lighting system

4*4 four-wheel drive

Full-time four driving force 0-36 km / h
Torque converter gearbox,
Open hydraulic gear oil pump.

Axles and tires

Aggravated special bridge, the planetary reduction gear, the flanged gear box
Rear axle, swing ($\pm 28^\circ$), and swinging frame on the bridge. Whole car is full frame, rear wheel double spring shock plate
Tires: 16-70-20PR, Maximum load: 5150kg, 450kPa

Brake

The device uses a butterfly service brake and an emergency brake to act on four wheels and uses a separate double parking brake.

Equipment hydraulic system

Aluminum heat exchanger for cooling hydraulic oil.
Open oil inlet, hydraulic oil filter can be replaced externally.

Stirring and unloading

The double cone Drum has a double spiral agitating screw and a convex bottom.
Drum geometry: 6100L
Drum rotation speed: 15 rpm.
Concrete production: 4.0 cubic meters / Drum

Steering

Articulated steering

Water supply system

"Self-suction" 24V large capacity pump with quick suction function.
Quantitative water supply controller, the mixing is more uniform and more comfortable with the standard.

Operating Cab

The enclosed operating room has a heating/cooling system with a sloping front window.
Humanize seat with flexible suspension and height adjustment.

Maintenance amount

Fuel tank: 135 liters
Hydraulic system Total capacity: 240 liters
Engine oil: 16 liters

Weight

Operating weight: 8800 kg
Maximum total weight: 18400 kg
Maximum load capacity: 9600 kg



Multi-directional discharge



Integral water tank



automatic buttering



10T hydraulic wheel drive axle



Adjustable speed of mixing



Hydraulic electronic scale



DEPARTURE SITE



DEPARTURE SITE



CONSTRUCTION SITE

pictures on the scene

